

CSC 252: Computer Organization

Spring 2021: Lecture 15

Instructor: Yuhao Zhu

Department of Computer Science
University of Rochester

Announcements

- Programming assignment 3 is **due today**
 - Details: <https://www.cs.rochester.edu/courses/252/spring2021/labs/assignment3.html>
 - Due on **March 23**, 11:59 PM
- Lab 2 grades are out.

7	8	9	10	11	12	13
14	15	16	17	18	19	20
21	22	23 Today Due	24	25 Mid-term	26	27

Announcements

- Mid-term exam: **this Thursday, 12:30 PM — 1:45 PM**; online.
- Past exam & Problem set: <https://www.cs.rochester.edu/courses/252/spring2021/handouts.html>
- Exam will be electronic using Gradescope, but we will send you an PDF version so that you can work offline in case
 - 1) you don't have stable Internet access at the exam time or
 - 2) the time doesn't work for you
 - Write down the answers on a scratch paper, take pictures, and send us the pictures
 - **Send me an email** explaining why you need to work offline before the exam data/time.

Announcements

- Exams are designed to test your ability to apply what you have learned and not your memory (though a good memory could help).
- Open book test: any sort of paper-based product, e.g., book, **notes**, magazine, old tests.
- **Nothing electronic (including laptop, cell phone, calculator, etc) other than the computer you use to take the exam.**
- You **can** use your electronic copy of the textbook, but you must not search in the textbook.
- **Nothing biological**, including your roommate, husband, wife, your hamster, another professor, etc.
- **“I don’t know”** gets 15% partial credit. Must erase everything else.

Announcements

- Mock exam now. Won't be graded.
- Go to <https://www.gradescope.com/courses/256242/assignments/1116540>.
- Log in using your NetID.

So far in 252...

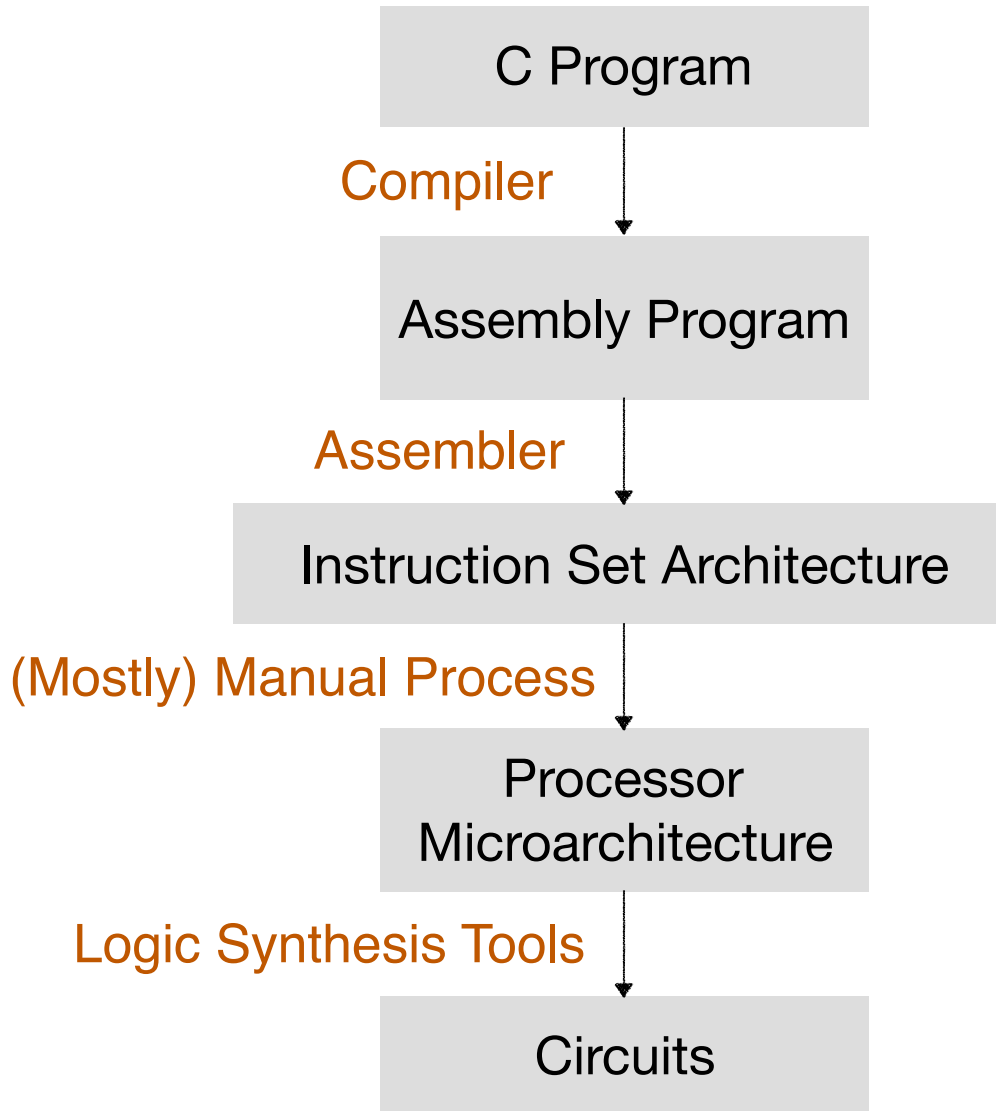

So far in 252...

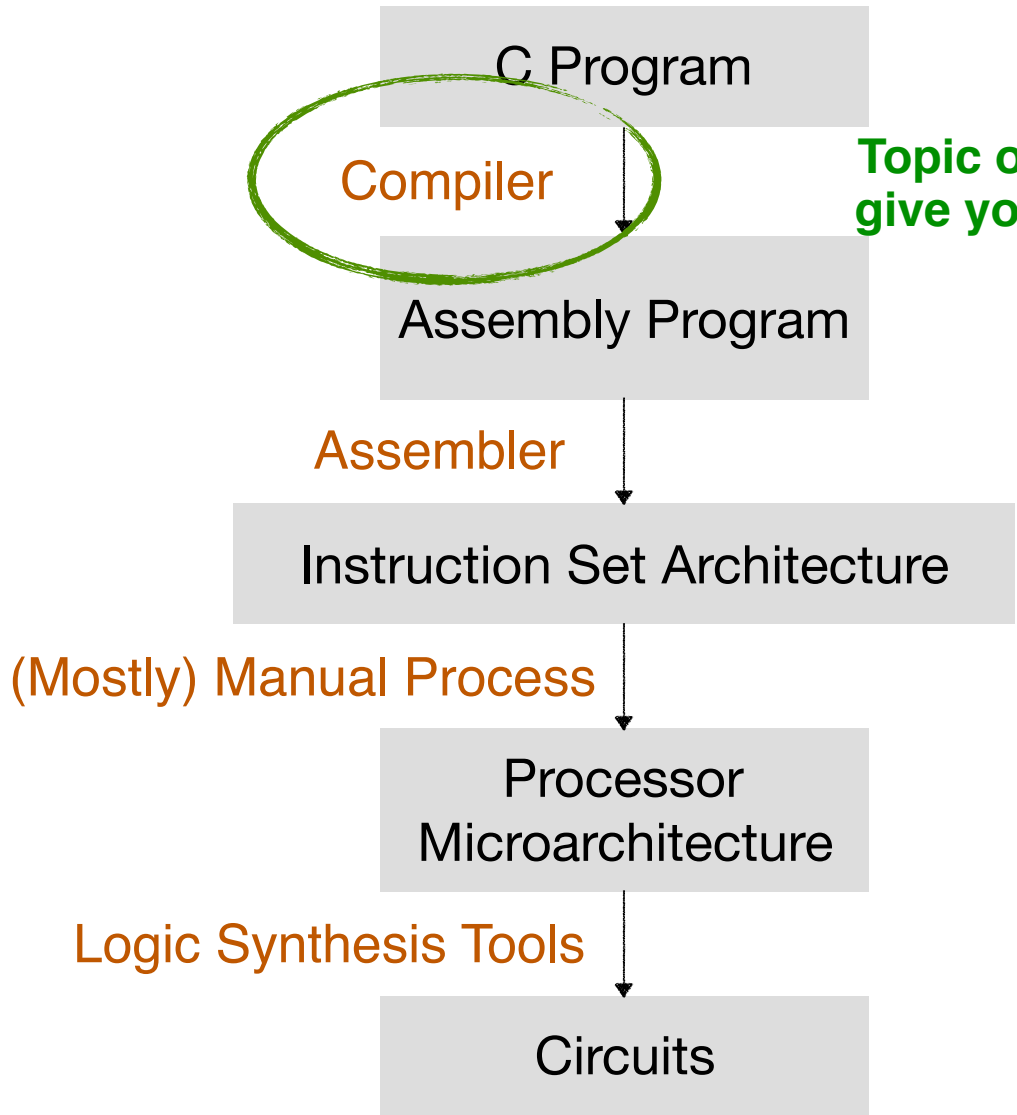

Topic of CSC 255, but we will give you some intuition here.

Code Optimization Overview

- Three entities can optimize the program: programmer, compiler, and hardware
- The best thing to speed up a program is to pick a good algorithm. Compilers/hardware can't do that in general.
 - Quicksort: $O(n \log n) = K * n * \log(n)$
 - Bubblesort: $O(n^2) = K * n^2$
- Algorithm choice decides overall complexity (big O), compiler/hardware decides the constant factor in the big O notation
- Compiler and hardware implementations decide the K.
- Programmers can write code that makes it easier to compiler and hardware to improve performance.

Optimizing Code Transformation

- Hardware/Microarchitecture Independent Optimizations
 - Code motion/precomputation
 - Strength reduction
 - Sharing of common subexpressions
- Optimization Blockers
 - Procedure calls
 - Memory aliasing
- Exploit Hardware Microarchitecture

Generally Useful Optimizations

- Optimizations that you or the compiler should do regardless of processor
- Code Motion
 - Reduce frequency with which computation performed
 - If it will always produce same result
 - Especially moving code out of loop

```
void set_row(double *a, double *b,  
            long i, long n)  
{  
    long j;  
    for (j = 0; j < n; j++)  
        a[n*i+j] = b[j];  
}
```



```
long j;  
int ni = n*i;  
for (j = 0; j < n; j++)  
    a[ni+j] = b[j];
```

Compiler-Generated Code Motion (-O1)

```
void set_row(double *a, double *b,
            long i, long n)
{
    long j;
    for (j = 0; j < n; j++)
        a[n*i+j] = b[j];
}
```

```
long j;
int ni = n*i;
for (j = 0; j < n; j++)
    a[ni+j] = b[j];
```

```
set_row:
    testq    %rcx, %rcx                # Test n
    jle     .L1                        # If 0, goto done
    imulq   %rcx, %rdx                # ni = n*i
    leaq    (%rdi,%rdx,8), %rdx        # rowp = A + ni*8
    movl    $0, %eax                  # j = 0
.L3:
    movsd   (%rsi,%rax,8), %xmm0       # t = b[j]
    movsd   %xmm0, (%rdx,%rax,8)       # M[A+ni*8 + j*8] = t
    addq    $1, %rax                  # j++
    cmpq    %rcx, %rax                # j:n
    jne     .L3                        # if !=, goto loop
.L1:
    rep ; ret                          # done:
```

Reduction in Strength

- Replace costly operation with simpler one
- Shift, add instead of multiply or divide
 - $16 * x \quad \text{-->} \quad x \ll 4$
 - Depends on cost of multiply or divide instruction
 - On Intel Nehalem, integer multiply requires 3 CPU cycles. Division takes even more cycles. Shift can generally be done in 1 cycle.
- Use the `leaq` instruction

Reduction in Strength

- Replace costly operation with simpler one
- Shift, add instead of multiply or divide
 - $16 * x \quad \text{-->} \quad x \ll 4$
 - Depends on cost of multiply or divide instruction
 - On Intel Nehalem, integer multiply requires 3 CPU cycles. Division takes even more cycles. Shift can generally be done in 1 cycle.
- Use the `leaq` instruction

```
long m12(long x)
{
    return x*12;
}
```

```
leaq (%rdi,%rdi,2), %rax # t <- x+x*2
salq $2, %rax           # return t<<2
```

Common Subexpression Elimination

- Reuse portions of expressions
- GCC will do this with `-O1`

3 multiplications: $i*n$, $(i-1)*n$, $(i+1)*n$

```
/* Sum neighbors of i,j */
up = val[(i-1)*n + j ];
down = val[(i+1)*n + j ];
left = val[i*n + j-1];
right = val[i*n + j+1];
sum = up + down + left + right;
```



```
leaq 1(%rsi), %rax # i+1
leaq -1(%rsi), %r8 # i-1
imulq %rcx, %rsi # i*n
imulq %rcx, %rax # (i+1)*n
imulq %rcx, %r8 # (i-1)*n
addq %rdx, %rsi # i*n+j
addq %rdx, %rax # (i+1)*n+j
addq %rdx, %r8 # (i-1)*n+j
```

1 multiplication: $i*n$

```
long inj = i*n + j;
up = val[inj - n];
down = val[inj + n];
left = val[inj - 1];
right = val[inj + 1];
sum = up + down + left + right;
```



```
imulq %rcx, %rsi # i*n
addq %rdx, %rsi # i*n+j
movq %rsi, %rax # i*n+j
subq %rcx, %rax # i*n+j-n
leaq (%rsi,%rcx), %rcx # i*n+j+n
```

Today: Optimizing Code Transformation

- Hardware/Microarchitecture Independent Optimizations
 - Code motion/precomputation
 - Strength reduction
 - Sharing of common subexpressions
- Optimization Blockers
 - Procedure calls
 - Memory aliasing
- Exploit Hardware Microarchitecture

Optimization Blocker #1: Procedure Calls

- Procedure to Convert String to Lower Case

```
void lower(char *s)
{
    size_t i;
    for (i = 0; i < strlen(s); i++)
        if (s[i] >= 'A' && s[i] <= 'Z')
            s[i] -= ('A' - 'a');
}
```

Calling Strlen

```
size_t strlen(const char *s)
{
    size_t length = 0;
    while (*s != '\0') {
        s++;
        length++;
    }
    return length;
}
```

- **Strlen performance**
 - Has to scan the entire length of a string, looking for null character.
 - $O(N)$ complexity
- **Overall performance**
 - N calls to `strlen`
 - Overall $O(N^2)$ performance

Improving Performance

- Move call to `strlen` outside of loop
- Since result does not change from one iteration to another
- Form of code motion

```
void lower(char *s)
{
    size_t i;
    size_t len = strlen(s);
    for (i = 0; i < len; i++)
        if (s[i] >= 'A' && s[i] <= 'Z')
            s[i] -= ('A' - 'a');
}
```

Optimization Blocker: Procedure Calls

```
void lower(char *s)
{
    size_t i;
    for (i = 0; i < strlen(s); i++)
        if (s[i] >= 'A' && s[i] <= 'Z')
            s[i] -= ('A' - 'a');
}
```

```
size_t total_lencount = 0;
size_t strlen(const char *s)
{
    size_t length = 0;
    while (*s != '\0') {
        s++; length++;
    }
    total_lencount += length;
    return length;
}
```

Why couldn't compiler move `strlen` out of loop?

- Procedure may have side effects, e.g., alters global state each time called
- Function may not return same value for given arguments

Optimization Blocker: Procedure Calls

- Most compilers treat procedure call as a black box
 - Assume the worst case, weak optimizations near them
 - There are interprocedural optimizations (IPO), but they are expensive
 - Sometimes the compiler doesn't have access to source code of other functions because they are object files in a library. Link-time optimizations (LTO) comes into play, but are expensive as well.

Optimization Blocker: Procedure Calls

- Most compilers treat procedure call as a black box
 - Assume the worst case, weak optimizations near them
 - There are interprocedural optimizations (IPO), but they are expensive
 - Sometimes the compiler doesn't have access to source code of other functions because they are object files in a library. Link-time optimizations (LTO) comes into play, but are expensive as well.
- Remedies:
 - Use of inline functions
 - Do your own code motion

Optimization Blocker: Procedure Calls

- Most compilers treat procedure call as a black box
 - Assume the worst case, weak optimizations near them
 - There are interprocedural optimizations (IPO), but they are expensive
 - Sometimes the compiler doesn't have access to source code of other functions because they are object files in a library. Link-time optimizations (LTO) comes into play, but are expensive as well.
- Remedies:
 - Use of inline functions
 - Do your own code motion

```
inline void swap(int *m, int *n) {  
    int tmp = *m;  
    *m = *n;  
    *n = tmp;  
}  
  
void foo () {  
    swap(&x, &y);  
}
```



```
void foo () {  
    int tmp = x;  
    x = y;  
    y = tmp;  
}
```

Optimization Blocker #2: Memory Aliasing

```
/* Sum rows of n X n matrix a
   and store in vector b */
void sum_rows1(double *a, double *b, long n) {
    long i, j;
    for (i = 0; i < n; i++) {
        b[i] = 0;
        for (j = 0; j < n; j++)
            b[i] += a[i*n + j];
    }
}
```

Value of a:

```
double a[9] =
{ 0, 1, 2,
  4, 8, 16,
  32, 64, 128};
```

Value of b:

```
init: [x, x, x]
```

Optimization Blocker #2: Memory Aliasing

```
/* Sum rows of n X n matrix a
   and store in vector b */
void sum_rows1(double *a, double *b, long n) {
    long i, j;
    for (i = 0; i < n; i++) {
        b[i] = 0;
        for (j = 0; j < n; j++)
            b[i] += a[i*n + j];
    }
}
```

Value of a:

```
double a[9] =
{ 0, 1, 2,
  4, 8, 16,
  32, 64, 128};
```

Value of b:

```
init: [x, x, x]
```

```
i = 0: [3, x, x]
```

Optimization Blocker #2: Memory Aliasing

```
/* Sum rows of n X n matrix a
   and store in vector b */
void sum_rows1(double *a, double *b, long n) {
    long i, j;
    for (i = 0; i < n; i++) {
        b[i] = 0;
        for (j = 0; j < n; j++)
            b[i] += a[i*n + j];
    }
}
```

Value of a:

```
double a[9] =
{ 0, 1, 2,
  4, 8, 16,
  32, 64, 128};
```

Value of b:

init: [x, x, x]

i = 0: [3, x, x]

i = 1: [3, 28, x]

Optimization Blocker #2: Memory Aliasing

```
/* Sum rows of n X n matrix a
   and store in vector b */
void sum_rows1(double *a, double *b, long n) {
    long i, j;
    for (i = 0; i < n; i++) {
        b[i] = 0;
        for (j = 0; j < n; j++)
            b[i] += a[i*n + j];
    }
}
```

Value of a:

```
double a[9] =
{ 0, 1, 2,
  4, 8, 16,
  32, 64, 128};
```

Value of b:

init: [x, x, x]

i = 0: [3, x, x]

i = 1: [3, 28, x]

i = 2: [3, 28, 224]

A Potential Optimization

```
/* Sum rows of n X n matrix a
   and store in vector b */
void sum_rows1(double *a, double *b, long n) {
    long i, j;
    for (i = 0; i < n; i++) {
        b[i] = 0;
        for (j = 0; j < n; j++)
            b[i] += a[i*n + j];
    }
}
```

Every iteration updates
memory location $b[i]$.
Memory accesses are
slow, so...

A Potential Optimization

```
/* Sum rows of n X n matrix a
   and store in vector b */
void sum_rows1(double *a, double *b, long n) {
    long i, j;
    for (i = 0; i < n; i++) {
        b[i] = 0;
        for (j = 0; j < n; j++)
            b[i] += a[i*n + j];
    }
}
```

Every iteration updates
memory location `b[i]`.
Memory accesses are
slow, so...



```
double val = 0;
for (j = 0; j < n; j++)
    val += a[i*n + j];
b[i] = val;
```

Every iteration updates `val`,
which could stay in register.
Update memory only once.

A Potential Optimization

```
/* Sum rows of n X n matrix a
   and store in vector b */
void sum_rows1(double *a, double *b, long n) {
    long i, j;
    for (i = 0; i < n; i++) {
        b[i] = 0;
        for (j = 0; j < n; j++)
            b[i] += a[i*n + j];
    }
}
```

Every iteration updates
memory location `b[i]`.
Memory accesses are
slow, so...

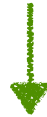

```
double val = 0;
for (j = 0; j < n; j++)
    val += a[i*n + j];
b[i] = val;
```

Every iteration updates `val`,
which could stay in register.
Update memory only once.

Why can't a compiler perform this optimization?

Memory Aliasing

```
/* Sum rows of n X n matrix a
   and store in vector b */
void sum_rows1(double *a, double *b, long n) {
    long i, j;
    for (i = 0; i < n; i++) {
        b[i] = 0;
        for (j = 0; j < n; j++)
            b[i] += a[i*n + j];
    }
}
```

Value of a:

```
double a[9] =
{ 0, 1, 2,
  4, 8, 16,
  32, 64, 128};
double b[3] = a+3;
sum_rows1(a, b, 3);
```

b

Value of b:

```
init: [4, 8, 16]
```

Memory Aliasing

```
/* Sum rows of n X n matrix a
   and store in vector b */
void sum_rows1(double *a, double *b, long n) {
    long i, j;
    for (i = 0; i < n; i++) {
        b[i] = 0;
        for (j = 0; j < n; j++)
            b[i] += a[i*n + j];
    }
}
```

Value of a:

b →

```
double a[9] =
{ 0, 1, 2,
  4, 8, 16,
  32, 64, 128};

double b[3] = a+3;

sum_rows1(a, b, 3);
```

Value of b:

init: [4, 8, 16]

i = 0: [3, 8, 16]

Memory Aliasing

```
/* Sum rows of n X n matrix a
   and store in vector b */
void sum_rows1(double *a, double *b, long n) {
    long i, j;
    for (i = 0; i < n; i++) {
        b[i] = 0;
        for (j = 0; j < n; j++)
            b[i] += a[i*n + j];
    }
}
```

Value of a:

b →

```
double a[9] =
{ 0, 1, 2,
  3, 8, 16,
  32, 64, 128};
double b[3] = a+3;
sum_rows1(a, b, 3);
```

Value of b:

init: [4, 8, 16]

i = 0: [3, 8, 16]

Memory Aliasing

```
/* Sum rows of n X n matrix a
   and store in vector b */
void sum_rows1(double *a, double *b, long n) {
    long i, j;
    for (i = 0; i < n; i++) {
        b[i] = 0;
        for (j = 0; j < n; j++)
            b[i] += a[i*n + j];
    }
}
```

Value of a:

b →

```
double a[9] =
{ 0, 1, 2,
  3, 0, 16,
  32, 64, 128};

double b[3] = a+3;

sum_rows1(a, b, 3);
```

Value of b:

init: [4, 8, 16]

i = 0: [3, 8, 16]

Memory Aliasing

```
/* Sum rows of n X n matrix a
   and store in vector b */
void sum_rows1(double *a, double *b, long n) {
    long i, j;
    for (i = 0; i < n; i++) {
        b[i] = 0;
        for (j = 0; j < n; j++)
            b[i] += a[i*n + j];
    }
}
```

Value of a:

b →

```
double a[9] =
{ 0, 1, 2,
  3, 3, 16,
  32, 64, 128};

double b[3] = a+3;

sum_rows1(a, b, 3);
```

Value of b:

init: [4, 8, 16]

i = 0: [3, 8, 16]

Memory Aliasing

```
/* Sum rows of n X n matrix a
   and store in vector b */
void sum_rows1(double *a, double *b, long n) {
    long i, j;
    for (i = 0; i < n; i++) {
        b[i] = 0;
        for (j = 0; j < n; j++)
            b[i] += a[i*n + j];
    }
}
```

Value of a:

b →

```
double a[9] =
{ 0, 1, 2,
  3, 6, 16,
  32, 64, 128};
double b[3] = a+3;
sum_rows1(a, b, 3);
```

Value of b:

init: [4, 8, 16]

i = 0: [3, 8, 16]

Memory Aliasing

```
/* Sum rows of n X n matrix a
   and store in vector b */
void sum_rows1(double *a, double *b, long n) {
    long i, j;
    for (i = 0; i < n; i++) {
        b[i] = 0;
        for (j = 0; j < n; j++)
            b[i] += a[i*n + j];
    }
}
```

Value of a:

b →

```
double a[9] =
{ 0, 1, 2,
  3, 22, 16,
  32, 64, 128};

double b[3] = a+3;

sum_rows1(a, b, 3);
```

Value of b:

init: [4, 8, 16]

i = 0: [3, 8, 16]

Memory Aliasing

```
/* Sum rows of n X n matrix a
   and store in vector b */
void sum_rows1(double *a, double *b, long n) {
    long i, j;
    for (i = 0; i < n; i++) {
        b[i] = 0;
        for (j = 0; j < n; j++)
            b[i] += a[i*n + j];
    }
}
```

Value of a:

b →

```
double a[9] =
{ 0, 1, 2,
  3, 22, 16,
  32, 64, 128};

double b[3] = a+3;

sum_rows1(a, b, 3);
```

Value of b:

init: [4, 8, 16]

i = 0: [3, 8, 16]

i = 1: [3, 22, 16]

Memory Aliasing

```
/* Sum rows of n X n matrix a
   and store in vector b */
void sum_rows1(double *a, double *b, long n) {
    long i, j;
    for (i = 0; i < n; i++) {
        b[i] = 0;
        for (j = 0; j < n; j++)
            b[i] += a[i*n + j];
    }
}
```

Value of a:

b →

```
double a[9] =
{ 0, 1, 2,
  3, 22, 16,
  32, 64, 128};

double b[3] = a+3;

sum_rows1(a, b, 3);
```

Value of b:

init: [4, 8, 16]

i = 0: [3, 8, 16]

i = 1: [3, 22, 16]

i = 2: [3, 22, 224]

Optimization Blocker: Memory Aliasing

- Aliasing
 - Two different memory references (array elements or pointers) specify the same memory location
 - Easy to have in C
 - Since C allows address/pointer arithmetic
 - Direct access to storage structures
 - Get in habit of introducing local variables
 - Accumulating within loops
 - Your way of telling compiler not to check for aliasing

Today: Optimizing Code Transformation

- Hardware/Microarchitecture Independent Optimizations
 - Code motion/precomputation
 - Strength reduction
 - Sharing of common subexpressions
- Optimization Blockers
 - Procedure calls
 - Memory aliasing
- Exploit Hardware Microarchitecture

Exploiting Instruction-Level Parallelism (ILP)

- Hardware can execute multiple instructions in parallel
 - Pipeline is a classic technique. Multiple instructions are being executed at the same time
- Performance limited by control/data dependencies
- Simple transformations can yield dramatic performance improvement
 - Compilers often cannot make these transformations
 - Lack of associativity and distributivity in floating-point arithmetic

Baseline Code

```
for (i = 0; i < length; i++) {  
    t = t * d[i];  
    *dest = t;  
}
```

.L519:

```
imulq (%rax,%rdx,4), %ecx  
addq $1, %rdx      # i++  
cmpq %rdx, %rbp   # Compare length:i  
jg .L519          # If >, goto Loop
```

← Real work

← Overhead

Loop Unrolling (2x1)

```
long limit = length-1;
long i;
/* Combine 2 elements at a time */
for (i = 0; i < limit; i+=2) {
    x = (x * d[i]) * d[i+1];
}

/* Finish any remaining elements */
for (; i < length; i++) {
    x = x * d[i];
}
*dest = x;
```

- Perform 2x more useful work per iteration
- Reduce loop overhead (comp, jmp, index dec, etc.)
- What's the trade-off here?

Loop Unrolling with Separate Accumulators

```
long limit = length-1;
long i;
/* Combine 2 elements at a time */
for (i = 0; i < limit; i+=2) {
    x0 = x0 * d[i];
    x1 = x1 * d[i+1];
}

/* Finish any remaining elements */
for (; i < length; i++) {
    x0 = x0 * d[i];
}
*dest = x0 * x1;
```

Data-Flow Graph (DFG)

```
x0 = x0 * d[i];  
x1 = x1 * d[i+1];
```

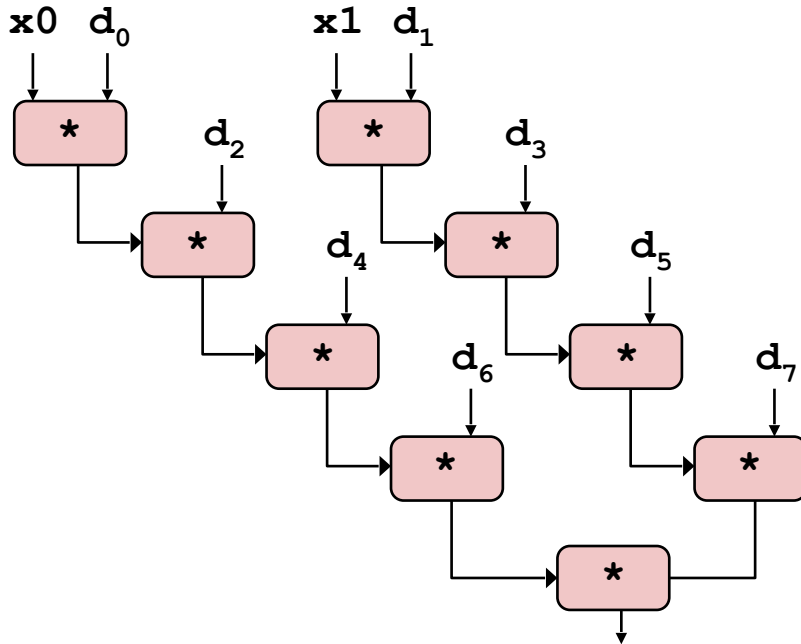

- What changed:
 - Two independent “streams” of operations
 - Reduce data dependency
- What was the DFG like using just one accumulator?

Code Optimization Summary

- From a programmer's perspective:
 - What you know: the functionality/intention of your code; the inputs to the program; all the code in the program
 - What you might not know: the hardware details.
- From a compiler's perspective:
 - What you know: all the code in the program; (maybe) the hardware details.
 - What you might not know: the inputs to the program; the intention of the code
- From the hardware's perspective:
 - What you know: the hardware details; some part of the code
 - What you might not know: the inputs to the program; the intention of the code
- The different perspectives indicate that different entities have different responsibilities, limitations, and advantages in optimizing the code

Aside: Profile-Guided Optimization

```
float foo(int x, int y)
{
    return pow(x, y) * 100 / log(x) * sqrt(y);
}
```

Aside: Profile-Guided Optimization

- As a programmer, if you know what x and y will be, say 5, you could direct return the results 23769.8 without having to the computation

```
float foo(int x, int y)
{
    return pow(x, y) * 100 / log(x) * sqrt(y);
}
```

Aside: Profile-Guided Optimization

- As a programmer, if you know what x and y will be, say 5, you could direct return the results 23769.8 without having to the computation
- Compiler would have no idea

```
float foo(int x, int y)
{
    return pow(x, y) * 100 / log(x) * sqrt(y);
}
```

Aside: Profile-Guided Optimization

- As a programmer, if you know what x and y will be, say 5, you could direct return the results 23769.8 without having to the computation
- Compiler would have no idea
- Except...Profile-guided optimizations:

```
float foo(int x, int y)
{
    return pow(x, y) * 100 / log(x) * sqrt(y);
}
```

Aside: Profile-Guided Optimization

- As a programmer, if you know what x and y will be, say 5, you could direct return the results 23769.8 without having to the computation
- Compiler would have no idea
- Except...Profile-guided optimizations:
 - Run the code multiple times using some sample inputs, and observe the values of x and y (statistically).

```
float foo(int x, int y)
{
    return pow(x, y) * 100 / log(x) * sqrt(y);
}
```

Aside: Profile-Guided Optimization

- As a programmer, if you know what x and y will be, say 5, you could direct return the results 23769.8 without having to the computation
- Compiler would have no idea
- Except...Profile-guided optimizations:
 - Run the code multiple times using some sample inputs, and observe the values of x and y (statistically).
 - If let's say 99% of the time, $x = 2$ and $y = 5$, what could the compiler do then?

```
float foo(int x, int y)
{
    return pow(x, y) * 100 / log(x) * sqrt(y);
}
```

Aside: Profile-Guided Optimization

- As a programmer, if you know what x and y will be, say 5, you could direct return the results 23769.8 without having to the computation
- Compiler would have no idea
- Except...Profile-guided optimizations:
 - Run the code multiple times using some sample inputs, and observe the values of x and y (statistically).
 - If let's say 99% of the time, $x = 2$ and $y = 5$, what could the compiler do then?

```
float foo(int x, int y)
{
    return pow(x, y) * 100 / log(x) * sqrt(y);
}
```

```
float foo(int x, int y)
{
    if (x == 2 && y == 5) return 23769.8;
    else return pow(x, y) * 100 / log(x) * sqrt(y);
}
```